



nyloprint[®] Combination CW 50 x 70

Largest compact all-in-one letterpress plate making system

Largest of the equipment combinations, suitable for processing water washable printing plates up to a maximum size of 500 x 700 mm (19.7" x 27.6")

High efficient and cost effective

- includes exposure, washout and drying unit for the production of high quality water washable letterpress plates
- space saving as all units can neatly be stacked on a trolley base
- each component can be (purchased and) used separately, as each has its own electrical connection
- long service life due to advanced materials – the casing of the equipment and all parts in contact with water are made of high quality stainless steel
- process safety due to programmed plate processing parameters and temperature controlled washout section
- for washout only tap water is needed
- less mechanical stress due to a proven plush washout system that prevents the washing away of fine elements
- oscillating plate holder ensures even plate washout and is self adjusting to allow the use of different plate thicknesses

Simple operating and convenient handling

- digital programmable operating panels for customising the processing times of each function
- audio alarm to signal end of each process
- trolley base with casters for easy movement and access to the system
- separate units for each process allows to easily replace or upgrade one part of the system if necessary

nyloprint® Combination CW 50 x 70

Equipment dimensions

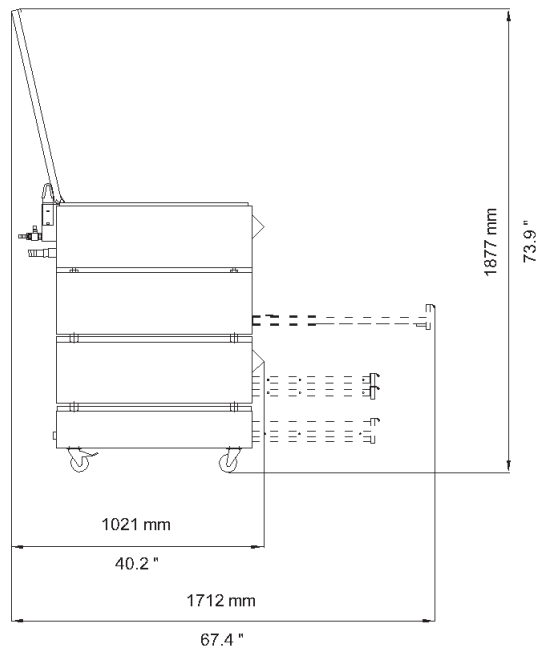
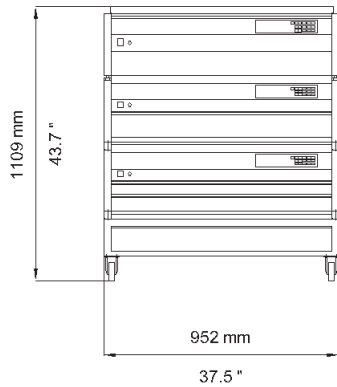

Technical data	Exposure	Washer	Dryer	Trolley
Max. plate size (W x L)	500 mm x 700 mm (19.7" x 27.6")			
Electrical connection	230 V, 50 Hz (1 Ph/N/PE) 230 V, 60 Hz (1 Ph/N/PE)	230 V, 50/60 Hz (1 Ph/N/PE)	230 V, 50/60 Hz (1 Ph/N/PE)	230 V / 400 V (AC)
Nominal current	7.2 A / 6.9 A	13.6 A	4.2 A	-
Nominal power	1.0 kW	3.2 kW	1.2 kW	5.4 kW
Exposure tubes	16 pcs., TL 40 W 10R (UV-A)	-	-	-
Fresh water connection	-	R 1/2"	-	-
Waste water connection	-	Ø 25 mm (0.984")	-	-
Dryer	-	-	2 drawers, heating element 2 x 500 W	-
Weight (approx.)	90 kg (198 lbs) net 108 kg (238 lbs) gross	85 kg (103 lbs) net 103 kg (227 lbs) gross	75 kg (165 lbs) net 93 kg (205 lbs) gross	38 kg (84 lbs) net 56 kg (123 lbs) gross
Crate dimensions (W x D x H)	1070 x 1050 x 495 mm (42.1" x 41.3" x 19.5")	1070 x 1050 x 495 mm (42.1" x 41.3" x 19.5")	1070 x 1050 x 495 mm (42.1" x 41.3" x 19.5")	982 x 860 x 495 mm (38.7" x 33.9" x 19.5")

You are welcome to contact us for further information.

Flint Group Germany GmbH
Sieglestrasse 25
70469 Stuttgart
Germany

T +49 711 9816-301
F +49 711 9816-801
info.flexo@flintgrp.com
www.flintgrp.com

All information in this document is based on our present knowledge and experience at the time of printing. Due to the multitude of factors influencing the processing and application of our products, it does not exempt the user from testing and calibrating. Nor does it imply any legally binding assurance concerning specific properties of the products or the suitability for a particular application. The responsibility of observing any possible industrial property rights, laws and regulations is the obligation of the user. Subject to technical changes without prior notice. Product names marked ® are registered trademarks of Flint Group.