



# nyloprint<sup>®</sup> Flowline Washer DWT 48

Compact, tankless flowline system for washout, drying and post exposure

Mid-size flowline combination, suitable for processing water washable printing plates up to a maximum width of 480 mm (18.9")

## High productivity and reliability due to excellent build quality

- flowline system for processing water washable printing plates – washout, rinsing, drying and UV-A post exposure all made automatically in line
- less mechanical stress due to a proven “plush” system that prevents the washing away of fine elements
- indication of water temperature and control of flowspeed
- direct water supply to reduce the level of contamination in the washout section, thus reducing downtime due to maintenance cleaning
- excellent build quality offering a long service life
- automatic lowering of squeegee roller

## Simple operation and convenient handling

- simple operation due to a touch screen
- single person operated system
- two easily adjustable plush carriers to suit different plate thicknesses
- low noise level during operation

## Additional components

- includes an “adhesive” carrier plate for processing foil based plates and a “magnetic” carrier plate for steel based plates

# nyloprint® Flowline Washer DWT 48

## Equipment dimensions

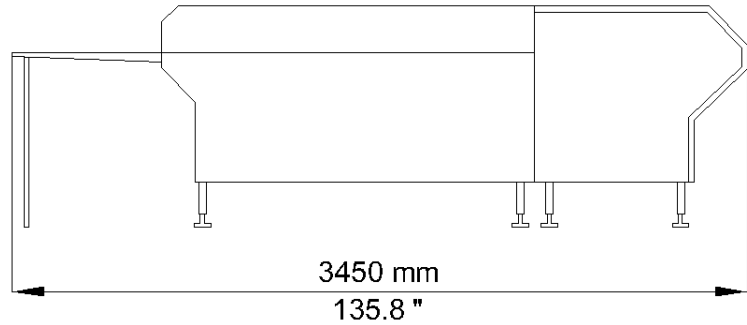
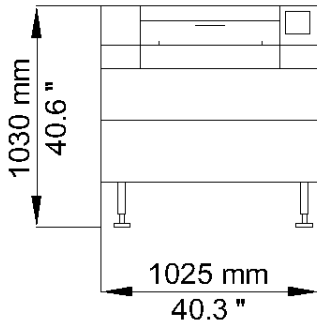

Technical data	nyloprint® Flowline Washer DWT 48
Maximum plate width	480 mm (18.9")
Electrical connection	230 V, 60 Hz (3 Ph/PE) / 400 V, 50 Hz (3 Ph/N/PE)
Nominal current	16 A / 10 A
Nominal power	5.0 kW
Fresh water connection	R ½", 2 - 4 bar (29 - 58 PSI)
Fresh water consumption	flow rate 0.3 m³/h (0.18 CFM) at 30 °C (86 °F)
Waste water connection	40 mm (1.6")
Exhaust air connection	Ø 50 mm (2")
Exhaust air flow rate	50 Nm³/h (30 CFM) (approx.)
Transport speed	40 - 350 mm/min (0.13 - 1.15 ft/min)
Post exposure tubes	6 pcs., TLK 40 W 10 R (UV-A), 590 mm (23.2")
Heating capacity of dryer	1 kW
Weight (approx.)	480 kg (1058 lbs) net 860 kg (1895 lbs) gross
Crate dimensions (W x D x H)	3050 x 1550 x 1500 mm (120.1" x 61.0" x 59.1")

You are welcome to contact us for further information.

**Flint Group Flexographic Products**  
Sieglestrasse 25  
70469 Stuttgart  
Germany

T +49 711 9816-301  
F +49 711 9816-801  
info.flexo@flintgrp.com  
www.flintgrp.com

All information in this document is based on our present knowledge and experience at the time of printing. Due to the multitude of factors influencing the processing and application of our products, it does not exempt the user from testing and calibrating. Nor does it imply any legally binding assurance concerning specific properties of the products or the suitability for a particular application. The responsibility of observing any possible industrial property rights, laws and regulations is the obligation of the user. Subject to technical changes without prior notice. Product names marked ® are registered trademarks of Flint Group.